



Northwest Business Park

7402-7648 Reindeer Trail, San Antonio, Texas

FOR LEASE

251,125 SF IN FIVE BUILDINGS

Available:

Ste. 7404	5,000 SF	Ste. 7496	8,877 SF
Ste. 7410	5,000 SF	Ste. 7506	9,000 SF
Ste. 7414	5,000 SF	Ste. 7562	6,000 SF
Ste. 7416	5,000 SF	Ste. 7566	4,500 SF
Ste. 7418	5,000 SF	Ste. 7588	12,500 SF
Ste. 7436	3,600 SF	Ste. 7634	12,000 SF
Ste. 7456	3,000 SF		

FEATURES:

- WAREHOUSE/DISTRIBUTION CENTER
- BUILT FROM 1980-1984
- DOCK HIGH /GRADE LEVEL LOADING
- CONCRETE TILT- WALL CONSTRUCTION
- I-1 ZONING



Glenn Villarreal
210.883.1304
210.240.0074
gvillarreal@henrysmiller.com

10123 Broadway, San Antonio, TX 78217

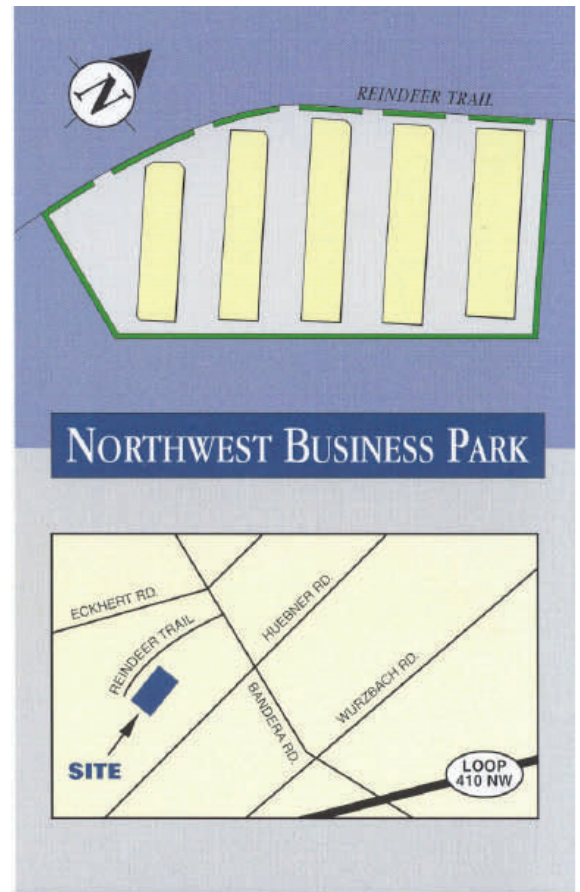

Henry S. Miller Commercial
Since 1914

THE INFORMATION CONTAINED HEREIN WAS OBTAINED FROM SOURCES BELIEVED RELIABLE; HOWEVER, HENRY S MILLER COMMERCIAL MAKE NO GUARANTEES, WARRANTIES OR REPRESENTATIONS AS TO THE COMPLETENESS OR ACCURACY THEREOF. THE PRESENTATION OF THIS PROPERTY IS SUBJECT TO ERRORS, OMISSIONS, CHANGE OF PRICE, OR CONDITIONS, PRIOR SALE OR LEASE, OR WITHDRAWAL WITHOUT NOTICE. TEXAS LAW REQUIRES LICEN-SEE TO DISCLOSE THAT IT IS REPRESENTING THE SELLER/ LANDORD IN THE MARKETING OF THIS PROPERTY.

7404 Reindeer Trail, San Antonio, Texas

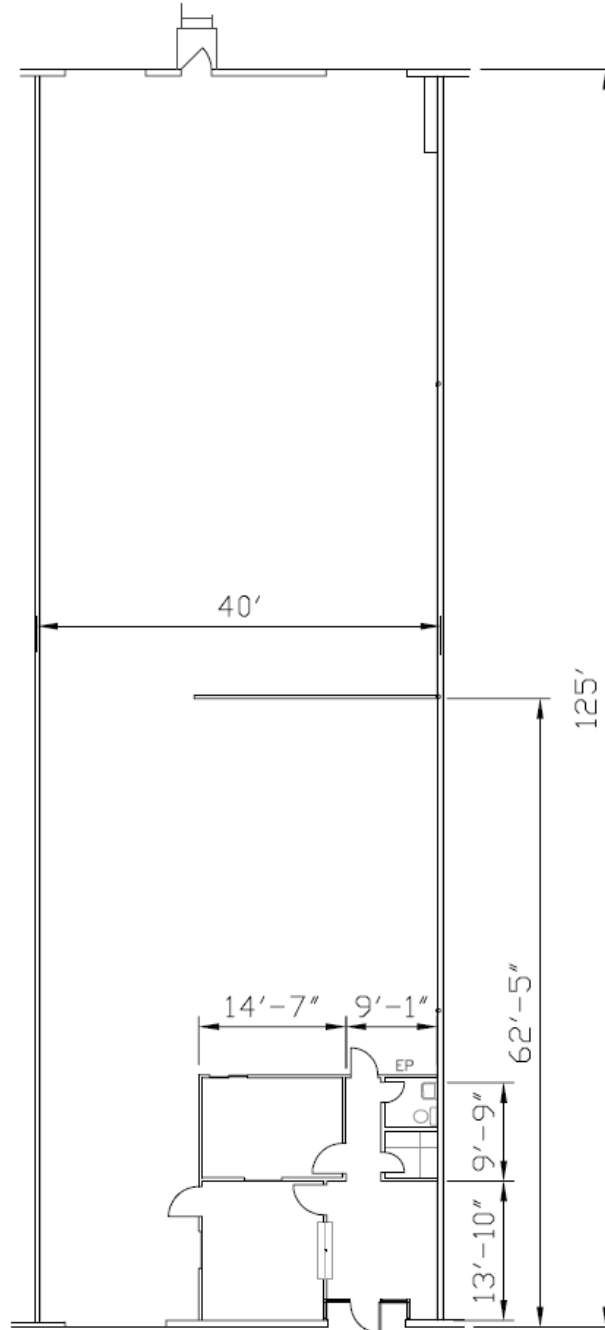

SCALE: 1/16" = 1'-0"

SPACE SUMMARY

LEASABLE AREA 5,000 sq. ft.
 OFFICE AREA 580 sq. ft.
 TRUCK DOORS Dock High: 2
 Grade Level: 1

BUILDING SUMMARY

AREA 251,125 sq. ft.
 LAND AREA 619,249 sq. ft.
 CLEAR CLG. HT. +/- 18'
 CONSTRUCTION Tilt Wall
 LIGHTING Fluorescent
 SPRINKLER 100%
 SLAB +/- 5"

LEGEND

GM Gas Meter
 WM Water Meter
 EP Electric Panel



Glenn Villarreal
210.883.1304
210.240.0074
gvillarreal@henrysmiller.com

10123 Broadway, San Antonio, TX 78217



THE INFORMATION CONTAINED HEREIN WAS OBTAINED FROM SOURCES BELIEVED RELIABLE; HOWEVER, HENRY S MILLER COMMERCIAL MAKE NO GUARANTEES, WARRANTIES OR REPRESENTATIONS AS TO THE COMPLETENESS OR ACCURACY THEREOF. THE PRESENTATION OF THIS PROPERTY IS SUBJECT TO ERRORS, OMISSIONS, CHANGE OF PRICE, OR CONDITIONS, PRIOR SALE OR LEASE, OR WITHDRAWAL WITHOUT NOTICE. TEXAS LAW REQUIRES LICEN-SEE TO DISCLOSE THAT IT IS REPRESENTING THE SELLER/ LANDORD IN THE MARKETING OF THIS PROPERTY.

7412 Reindeer Trail, San Antonio, Texas

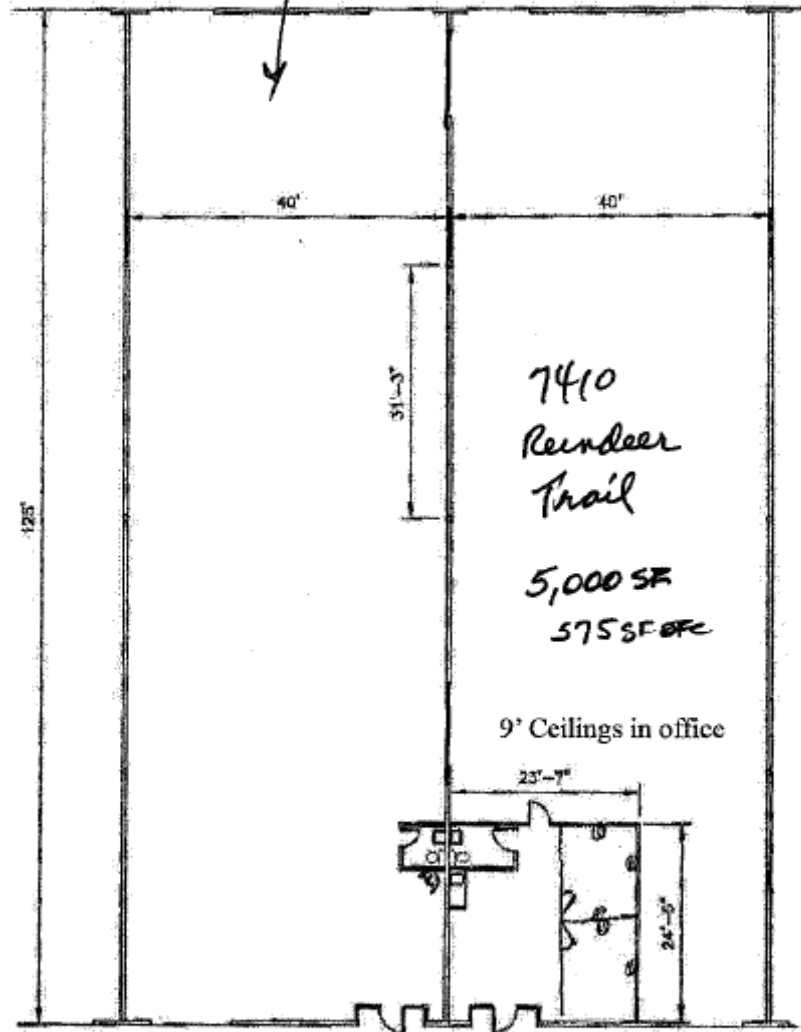

SCALE: 1/16" = 1'-0"

SPACE SUMMARY	BUILDING SUMMARY	LEGEND
LEASABLE AREA OFFICE AREAS TRUCK DOORS	AREA LAND AREA CLEAR CLS. HT. +/- CONSTRUCTION LIGHTING SPRINKLER SLAB +/-	GM WM EP TB Wall Fluorescent 100% 9'
10,000 sq. ft. 800 sq. ft. Dock High 4 Grade Level 3	251,125 sq. ft. 618,240 sq. ft. 18 100% 9'	Gas Meter Water Meter Electric Panel



Glenn Villarreal
210.883.1304
210.240.0074
gvillarreal@henrysmiller.com

10123 Broadway, San Antonio, TX 78217



Henry S. Miller Commercial
Since 1914

THE INFORMATION CONTAINED HEREIN WAS OBTAINED FROM SOURCES BELIEVED RELIABLE; HOWEVER, HENRY S MILLER COMMERCIAL MAKE NO GUARANTEES, WARRANTIES OR REPRESENTATIONS AS TO THE COMPLETENESS OR ACCURACY THEREOF. THE PRESENTATION OF THIS PROPERTY IS SUBJECT TO ERRORS, OMISSIONS, CHANGE OF PRICE, OR CONDITIONS, PRIOR SALE OR LEASE, OR WITHDRAWAL WITHOUT NOTICE. TEXAS LAW REQUIRES LICENSE TO DISCLOSE THAT IT IS REPRESENTING THE SELLER/ LANDORD IN THE MARKETING OF THIS PROPERTY.

7416 Reindeer Trail, San Antonio, Texas

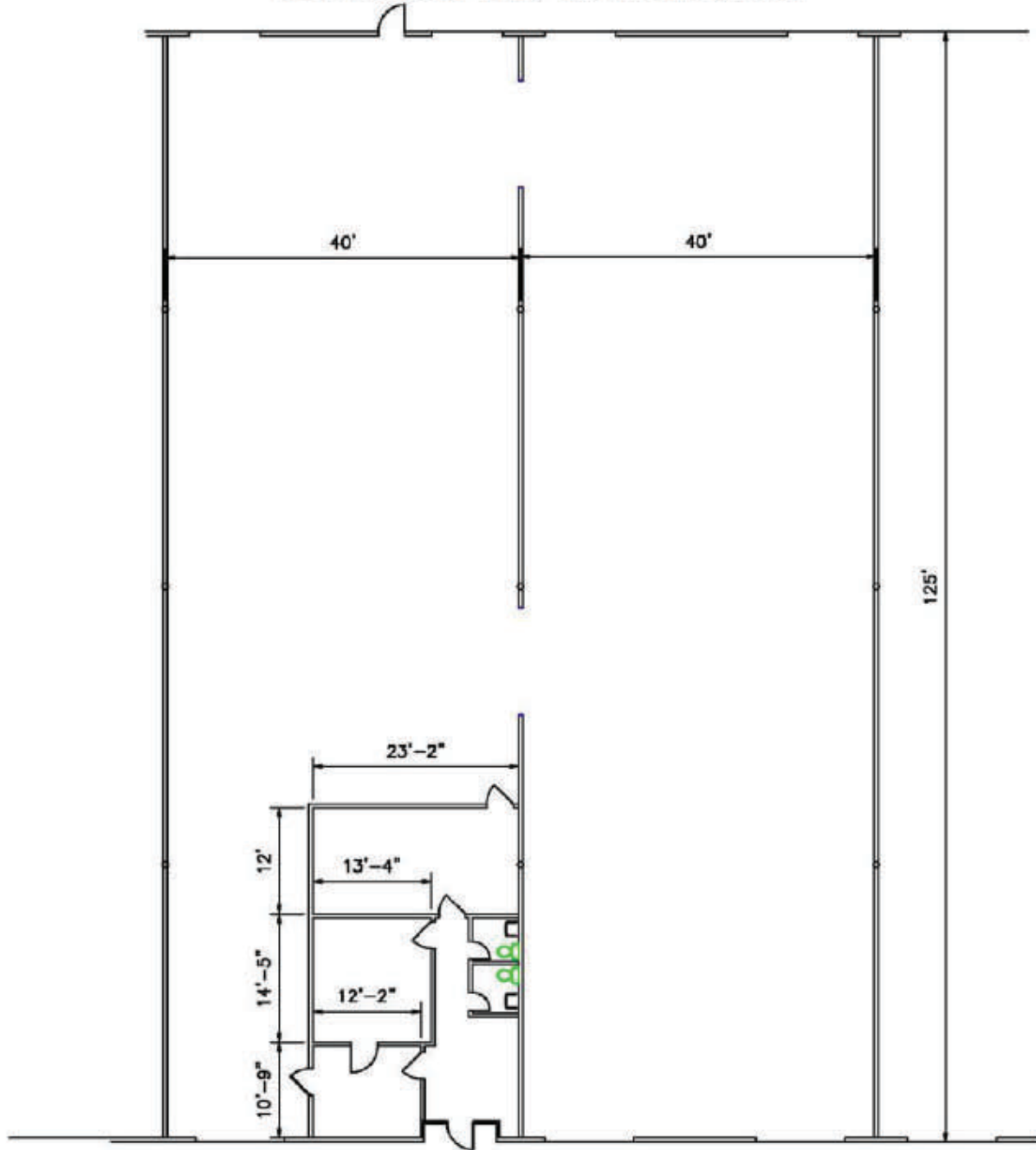

SCALE: 1/16" = 1'-0"

SPACE SUMMARY

7416 LEASABLE AREA 10,000 sq. ft.
 OFFICE AREA 886 sq. ft.
 TRUCK DOORS Dock High: 4
 Grade Level: 3

BUILDING SUMMARY

AREA
 LAND AREA
 CLEAR CLG. HT. +/-
 CONSTRUCTION
 LIGHTING
 SPRINKLER
 SLAB +/-

251,125 sq. ft.
 819,249 sq. ft.
 18'
 Tile Wall
 Fluorescent
 100%
 5"

LEGEND

GM Gas Meter
 WM Water Meter
 EP Electric Panel



Glenn Villarreal
210.883.1304
210.240.0074
gvillarreal@henrysmiller.com

10123 Broadway, San Antonio, TX 78217



THE INFORMATION CONTAINED HEREIN WAS OBTAINED FROM SOURCES BELIEVED RELIABLE; HOWEVER, HENRY S MILLER COMMERCIAL MAKE NO GUARANTEES, WARRANTIES OR REPRESENTATIONS AS TO THE COMPLETENESS OR ACCURACY THEREOF. THE PRESENTATION OF THIS PROPERTY IS SUBJECT TO ERRORS, OMISSIONS, CHANGE OF PRICE, OR CONDITIONS, PRIOR SALE OR LEASE, OR WITHDRAWAL WITHOUT NOTICE. TEXAS LAW REQUIRES LICENSEE TO DISCLOSE THAT IT IS REPRESENTING THE SELLER/ LANDORD IN THE MARKETING OF THIS PROPERTY.

7418 REINBERG TRAIL
5048 SF TOTAL
705 SF OFFICE

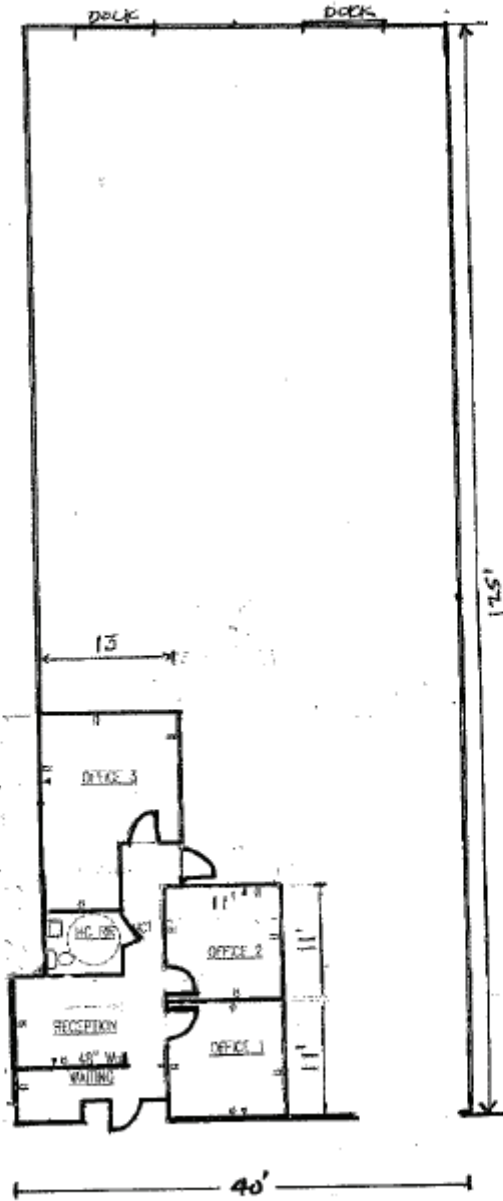

Glenn Villarreal
210.883.1304
210.240.0074
gvillarreal@henrysmiller.com

10123 Broadway, San Antonio, TX 78217



Henry S. Miller Commercial
Since 1914

THE INFORMATION CONTAINED HEREIN WAS OBTAINED FROM SOURCES BELIEVED RELIABLE; HOWEVER, HENRY S MILLER COMMERCIAL MAKE NO GUARANTEES, WARRANTIES OR REPRESENTATIONS AS TO THE COMPLETENESS OR ACCURACY THEREOF. THE PRESENTATION OF THIS PROPERTY IS SUBJECT TO ERRORS, OMISSIONS, CHANGE OF PRICE, OR CONDITIONS, PRIOR SALE OR LEASE, OR WITHDRAWAL WITHOUT NOTICE. TEXAS LAW REQUIRES LICENSEE TO DISCLOSE THAT IT IS REPRESENTING THE SELLER/ LANDORD IN THE MARKETING OF THIS PROPERTY.

7436 Reindeer Trail, San Antonio, Texas

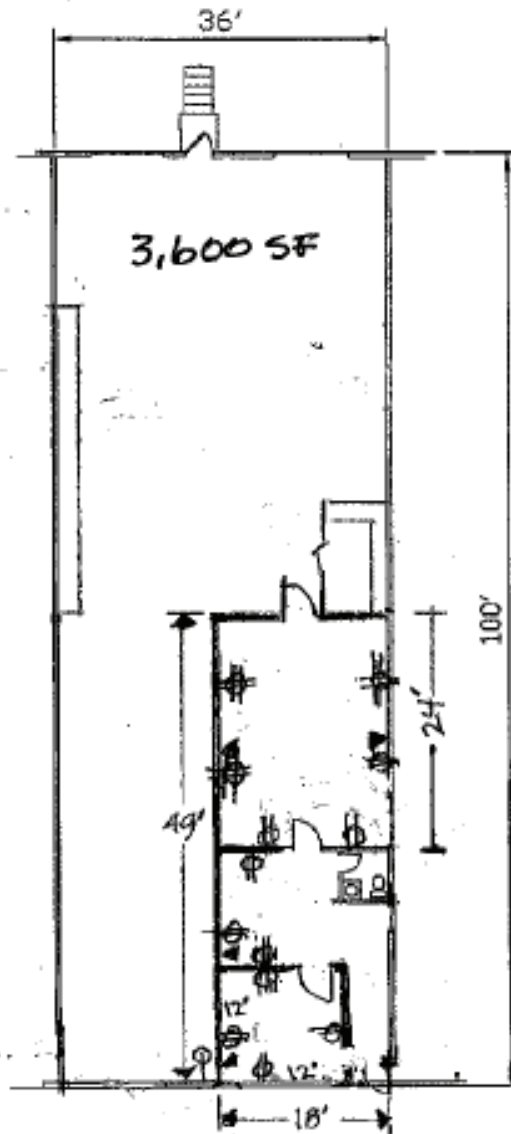

SCALE: 1/16" = 1'-0"

SPACE SUMMARY

LEASEABLE AREA
OFFICE AREA
TRUCK DOORS

sq. ft.
+/- ft.
Clear Height 2
Grade Level: 1

BUILDING SUMMARY

AREA
LAND AREA
CLEAR CLG. HT. +/-
CONSTRUCTION
LIGHTING
SPRINKLER
SLAB +/-

251,125 sq. ft.
880,348 sq. ft.
18'
TH Wall
Fluorescent
100%
9"

LEGEND

GM
VM
SP

Gas Meter
Water Meter
Electric Panel



Glenn Villarreal
210.883.1304
210.240.0074
gvillarreal@henrysmiller.com

10123 Broadway, San Antonio, TX 78217



Henry S. Miller Commercial
Since 1914

THE INFORMATION CONTAINED HEREIN WAS OBTAINED FROM SOURCES BELIEVED RELIABLE; HOWEVER, HENRY S MILLER COMMERCIAL MAKE NO GUARANTEES, WARRANTIES OR REPRESENTATIONS AS TO THE COMPLETENESS OR ACCURACY THEREOF. THE PRESENTATION OF THIS PROPERTY IS SUBJECT TO ERRORS, OMISSIONS, CHANGE OF PRICE, OR CONDITIONS, PRIOR SALE OR LEASE, OR WITHDRAWAL WITHOUT NOTICE. TEXAS LAW REQUIRES LICENSEE TO DISCLOSE THAT IT IS REPRESENTING THE SELLER/ LANDORD IN THE MARKETING OF THIS PROPERTY.

AVAILABLE

7456 Reindeer Trail, San Antonio, Texas

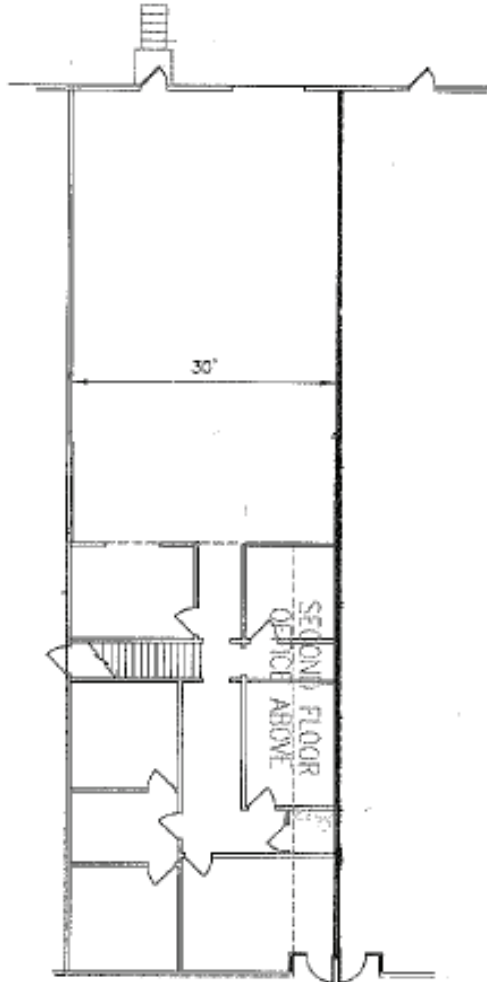

SCALE: 1/16" = 1'-0"

SPACE SUMMARY

LEASABLE AREA
OFFICE AREA
TRUCK DOORS

3000 sq. ft.
14700 sq. ft.
Dock High:
Grade Level:

BUILDING SUMMARY

AREA
LAND AREA
CLEAR CLG. HT. +/-
CONSTRUCTION
LIGHTING
SPRINKLER

251,125 sq. ft.
519,248 sq. ft.
18'
Tile Wall
Fluorescent
100%

LEGEND

GM
WM
EP

Gas Meter
Water Meter
Electric Panel



Glenn Villarreal
210.883.1304
210.240.0074
gvillarreal@henrysmiller.com

10123 Broadway, San Antonio, TX 78217



Henry S. Miller Commercial
Since 1914

THE INFORMATION CONTAINED HEREIN WAS OBTAINED FROM SOURCES BELIEVED RELIABLE; HOWEVER, HENRY S MILLER COMMERCIAL MAKE NO GUARANTEES, WARRANTIES OR REPRESENTATIONS AS TO THE COMPLETENESS OR ACCURACY THEREOF. THE PRESENTATION OF THIS PROPERTY IS SUBJECT TO ERRORS, OMISSIONS, CHANGE OF PRICE, OR CONDITIONS, PRIOR SALE OR LEASE, OR WITHDRAWAL WITHOUT NOTICE. TEXAS LAW REQUIRES LICENSEE TO DISCLOSE THAT IT IS REPRESENTING THE SELLER/ LANDORD IN THE MARKETING OF THIS PROPERTY.

AVAILABLE

7496 Reindeer Trail, San Antonio, Texas

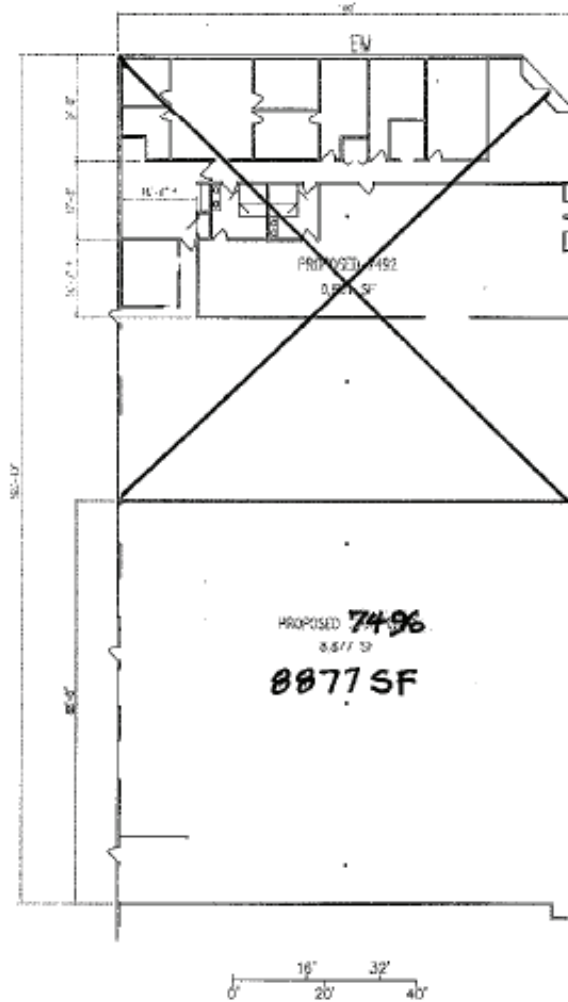

SPACE SUMMARY

LEASABLE AREA
OFFICE AREA
TRUCK DOORS

8877 sq. ft.
511,000 sq. ft.
Dock High
Grade Level

BUILDING SUMMARY

AREA
LAND AREA
CLEAR CLG. HT. +/-
CONSTRUCTION
LIGHTING
SPRINKLER
SLAB +/-

251,125 sq. ft.
610,240 sq. ft.
18'
TR Wall
Fluorescent
100%
5"

LEGEND

GM
WM
EP
Gas Meter
Water Meter
Electric Panel



Glenn Villarreal
210.883.1304
210.240.0074
gvillarreal@henrysmiller.com

10123 Broadway, San Antonio, TX 78217



Henry S. Miller Commercial
Since 1914

THE INFORMATION CONTAINED HEREIN WAS OBTAINED FROM SOURCES BELIEVED RELIABLE; HOWEVER, HENRY S MILLER COMMERCIAL MAKE NO GUARANTEES, WARRANTIES OR REPRESENTATIONS AS TO THE COMPLETENESS OR ACCURACY THEREOF. THE PRESENTATION OF THIS PROPERTY IS SUBJECT TO ERRORS, OMISSIONS, CHANGE OF PRICE, OR CONDITIONS, PRIOR SALE OR LEASE, OR WITHDRAWAL WITHOUT NOTICE. TEXAS LAW REQUIRES LICENSE TO DISCLOSE THAT IT IS REPRESENTING THE SELLER/ LANDORD IN THE MARKETING OF THIS PROPERTY.

7562 Reindeer Trail, San Antonio, Texas

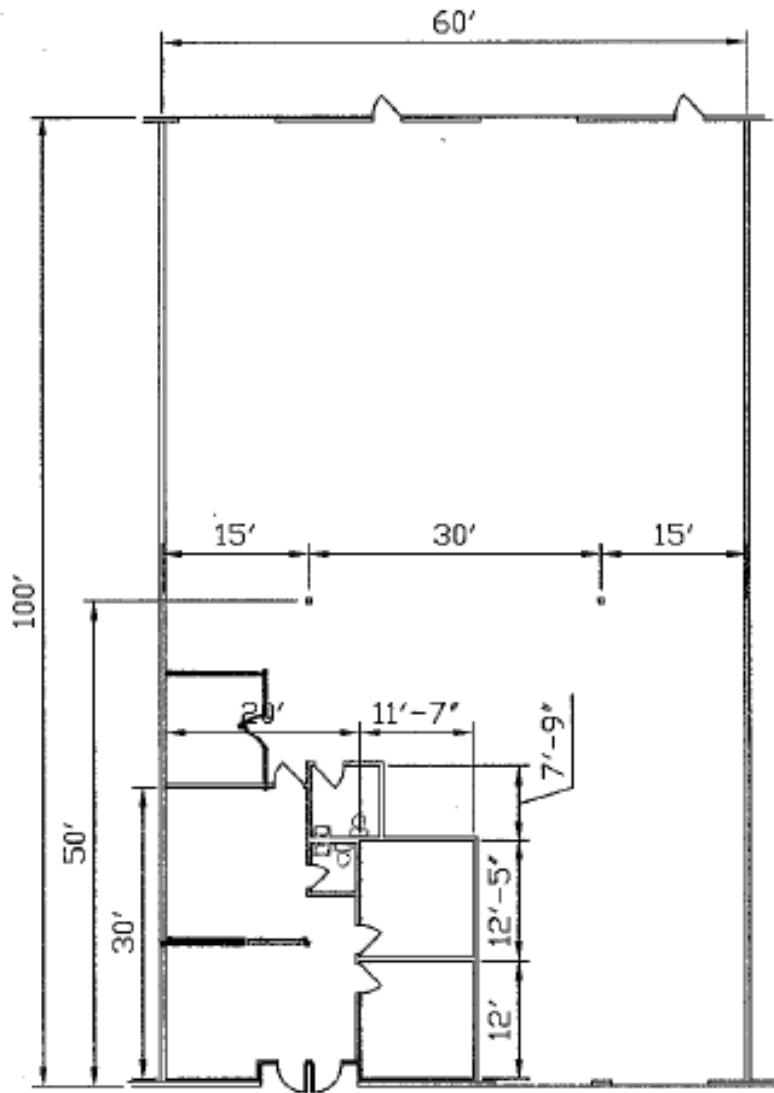

SCALE: 1"=10'

SPACE SUMMARY

LEASABLE AREA
OFFICE AREA
TRUCK DOORS

6,000 sq. ft.
944 sq. ft.
Dock High 2
GRADE LEVEL 2

BUILDING SUMMARY

AREA
LAND AREA
CLEAR CLG. HT. +/-
CONSTRUCTION
LIGHTING
SPRINKLER
SLAB +/-

291,125 sq. ft.
819,248 sq. ft.
18'
TN Wall
Fluorescent
100%
5"

LEGEND

GM
WM
EP

Gas Meter
Water Meter
Electric Panel



Glenn Villarreal
210.883.1304
210.240.0074
gvillarreal@henrysmiller.com

10123 Broadway, San Antonio, TX 78217



Henry S. Miller Commercial
Since 1914

THE INFORMATION CONTAINED HEREIN WAS OBTAINED FROM SOURCES BELIEVED RELIABLE; HOWEVER, HENRY S MILLER COMMERCIAL MAKE NO GUARANTEES, WARRANTIES OR REPRESENTATIONS AS TO THE COMPLETENESS OR ACCURACY THEREOF. THE PRESENTATION OF THIS PROPERTY IS SUBJECT TO ERRORS, OMISSIONS, CHANGE OF PRICE, OR CONDITIONS, PRIOR SALE OR LEASE, OR WITHDRAWAL WITHOUT NOTICE. TEXAS LAW REQUIRES LICENSEE TO DISCLOSE THAT IT IS REPRESENTING THE SELLER/ LANDORD IN THE MARKETING OF THIS PROPERTY.

7580-7584 Reindeer Trail, San Antonio, Texas

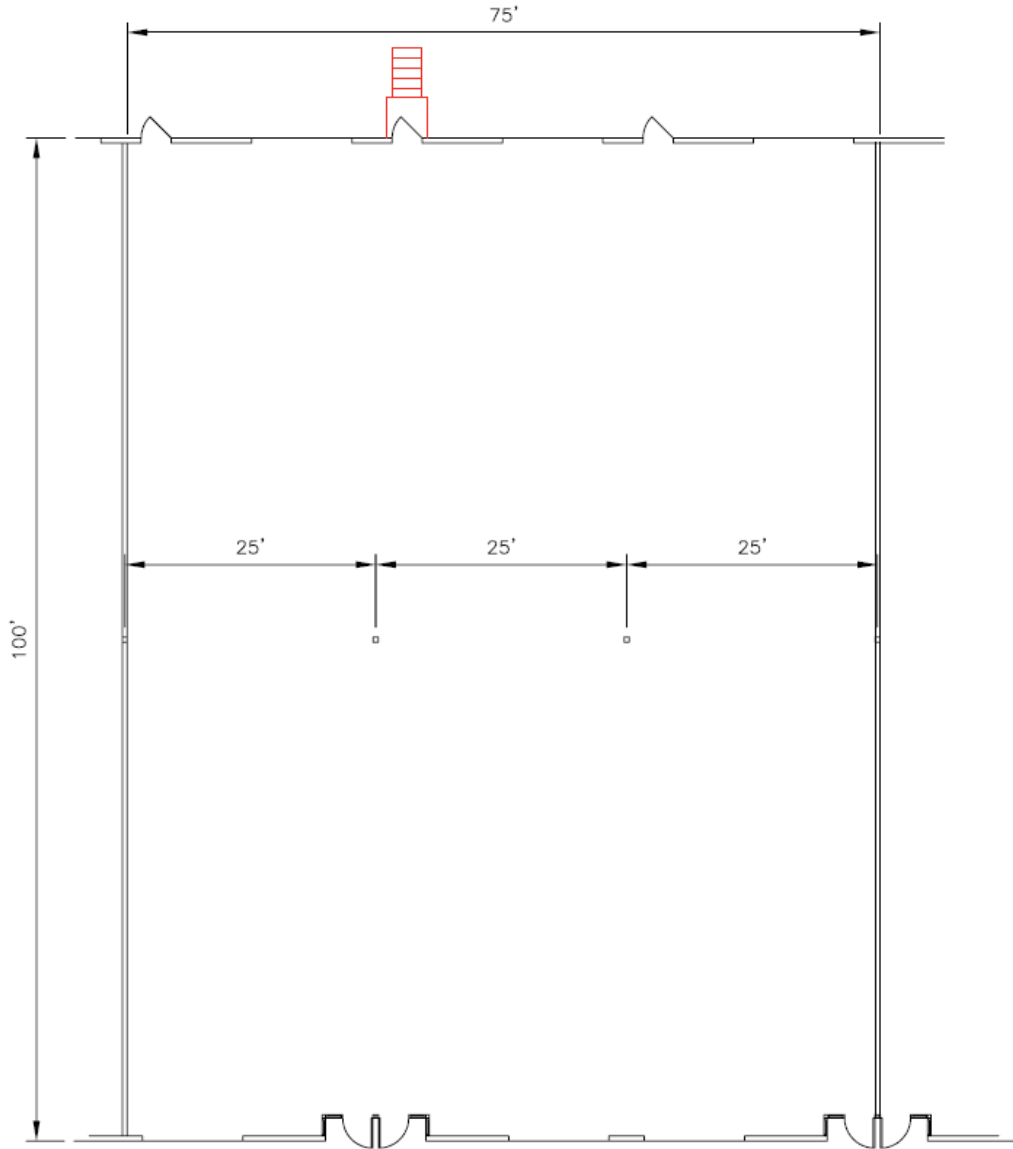

SCALE: 1/16" = 1'-0"

SPACE SUMMARY

LEASABLE AREA 7,500 sq. ft.
 OFFICE AREA N/A
 TRUCK DOORS Dock Hlgh: 3
 Grade Level: 3

BUILDING SUMMARY

AREA 251,125 sq. ft.
 LAND AREA 619,249 sq. ft.
 CLEAR CLG. HT. +/- 18'
 CONSTRUCTION Tilt Wall
 LIGHTING Fluorescent
 SPRINKLER 100%
 SLAB +/- 5"

LEGEND

GM Gas Meter
 WM Water Meter
 EP Electric Panel



Glenn Villarreal
210.883.1304
210.240.0074
gvillarreal@henrysmiller.com

10123 Broadway, San Antonio, TX 78217



THE INFORMATION CONTAINED HEREIN WAS OBTAINED FROM SOURCES BELIEVED RELIABLE; HOWEVER, HENRY S MILLER COMMERCIAL MAKE NO GUARANTEES, WARRANTIES OR REPRESENTATIONS AS TO THE COMPLETENESS OR ACCURACY THEREOF. THE PRESENTATION OF THIS PROPERTY IS SUBJECT TO ERRORS, OMISSIONS, CHANGE OF PRICE, OR CONDITIONS, PRIOR SALE OR LEASE, OR WITHDRAWAL WITHOUT NOTICE. TEXAS LAW REQUIRES LICENSE TO DISCLOSE THAT IT IS REPRESENTING THE SELLER/ LANDORD IN THE MARKETING OF THIS PROPERTY.

7586-7588 Reindeer Trail, San Antonio, Texas

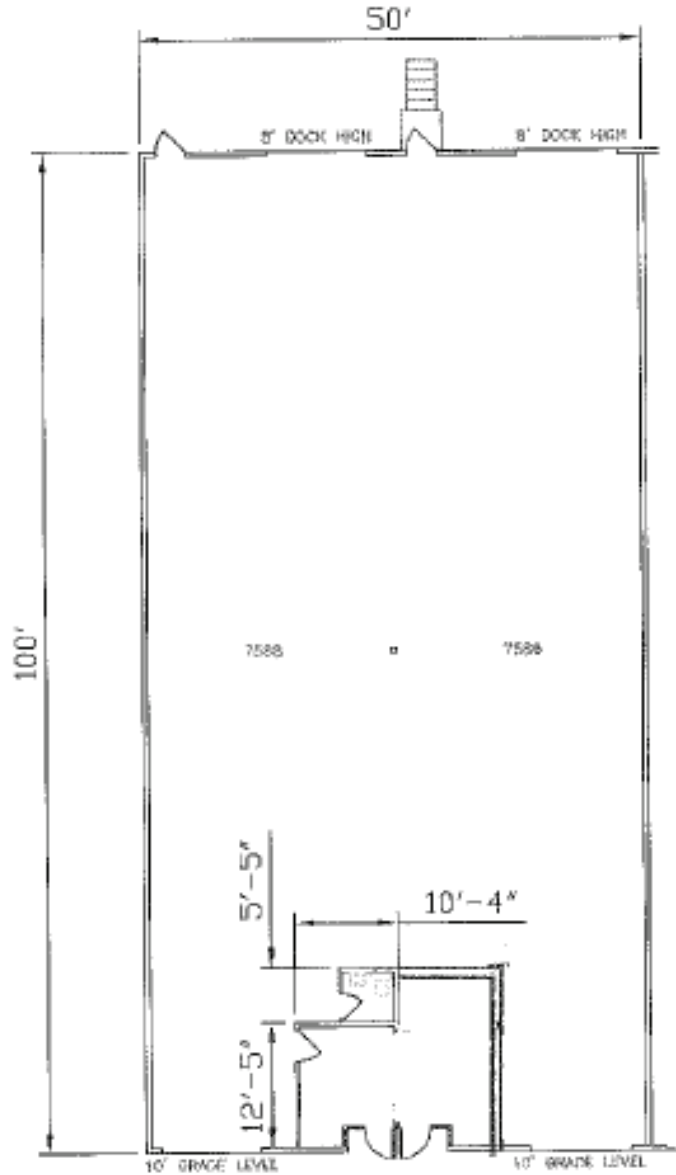

SCALE: 1"=10'

SPACE SUMMARY

LEASABLE AREA
OFFICE AREA
TRUCK DOORS

5,000 sq. ft.
310 sq. ft.
Dock High: 2
Grade Level: 2

BUILDING SUMMARY

AREA
LAND AREA
CLEAR CLG. HT. +/-
CONSTRUCTION
LIGHTING
SPRINKLER
SLAB +/-

251,125 sq. ft.
810,249 sq. ft.
18'
Tilt Wall
Fluorescent
100%
5"

LEGEND

GM
WM
EP

Gas Meter
Water Meter
Electric Panel



Glenn Villarreal
210.883.1304
210.240.0074
gvillarreal@henrysmiller.com

10123 Broadway, San Antonio, TX 78217



Henry S. Miller Commercial
Since 1914

THE INFORMATION CONTAINED HEREIN WAS OBTAINED FROM SOURCES BELIEVED RELIABLE; HOWEVER, HENRY S MILLER COMMERCIAL MAKE NO GUARANTEES, WARRANTIES OR REPRESENTATIONS AS TO THE COMPLETENESS OR ACCURACY THEREOF. THE PRESENTATION OF THIS PROPERTY IS SUBJECT TO ERRORS, OMISSIONS, CHANGE OF PRICE, OR CONDITIONS, PRIOR SALE OR LEASE, OR WITHDRAWAL WITHOUT NOTICE. TEXAS LAW REQUIRES LICENSE TO DISCLOSE THAT IT IS REPRESENTING THE SELLER/ LANDORD IN THE MARKETING OF THIS PROPERTY.

INFORMATION ABOUT BROKERAGE SERVICES

Texas law requires all real estate licensees to give the following information about brokerage services to prospective buyers, tenants, sellers and landlords.

Before working with a real estate broker, you should know that the duties of a broker depend on whom the broker represents. If you are a prospective seller/landlord or a prospective buyer/tenant, you should know that the broker who lists the property for sale or lease is the seller/landlord's agent. A broker who acts as a subagent represents the seller/landlord in cooperation with the listing broker. A broker who acts as a buyer/tenant's agent represents the buyer/tenant. A broker may act as an intermediary between the parties if the parties consent in writing. A broker can assist you in locating a property, preparing a contract or lease, or obtaining financing without representing you. A broker is obligated by law to treat you honestly.

IF THE BROKER REPRESENTS THE SELLER/LANDLORD:

The broker becomes the seller/landlord's agent by entering into an agreement with the seller/landlord, usually through a written listing agreement, or by agreeing to act as a subagent by accepting an offer of subagency from the listing broker. A subagent may work in a different real estate office. A listing broker or subagent can assist the buyer/tenant but does not represent the buyer/tenant and must place the interests of the seller/landlord first. The buyer/tenant should not tell the seller/landlord's agent anything the buyer/tenant would not want the seller/landlord to know because a seller/landlord's agent must disclose to the seller/landlord any material information known to the agent.

IF THE BROKER REPRESENTS THE BUYER/TENANT:

The broker becomes the buyer/tenant's agent by entering into an agreement to represent the buyer/tenant, usually through a written buyer/tenant representation agreement. A buyer/tenant's agent can assist the seller/landlord but does not represent the owner/landlord and must place the interests of the buyer/tenant first. The seller/landlord should not tell a buyer/tenant's agent anything the seller/landlord would not want the buyer/tenant to know because a buyer/tenant's agent must disclose to the buyer/tenant any material information known to the agent.

IF THE BROKER ACTS AS AN INTERMEDIARY:

A broker may act as an intermediary between the parties if the broker complies with The Texas Real Estate License Act. The broker must obtain the written consent of each party to the transaction to act as an intermediary. The written consent must state who will pay the broker and, in conspicuous bold or underlined print, set forth the broker's obligations as an intermediary. The broker is required to treat each party honestly and fairly and to comply with The Texas Real Estate License Act. A broker who acts as an intermediary in a transaction:

- 1) shall treat all parties honestly;
- 2) may not disclose that the seller/landlord will accept a price less than the asking price unless authorized in writing to do so by the seller/landlord;
- 3) may not disclose that the buyer/tenant will pay a price greater than the price submitted in a written offer unless authorized in writing to do so by the buyer/tenant; and
- 4) may not disclose any confidential information or any information that a party specifically instructs the broker in writing not to disclose unless authorized in writing to disclose the information or required to do so by The Texas Real Estate License Act or a court order or if the information materially relates to the condition of the property.

With the parties' consent, a broker acting as an intermediary between the parties may appoint a person who is licensed under The Texas Real Estate License Act and associated with the broker to communicate with and carry out instructions of one party and another person who is licensed under that Act and associated with the broker to communicate with and carry out instructions of the other party.

If you choose to have a broker represent you,

you should enter into a written agreement with the broker that clearly establishes the broker's obligations and your obligations. The agreement should state how and by whom the broker will be paid. You have the right to choose the type of representation, if any, you wish to receive. Your payment of a fee to a broker does not necessarily establish that the broker represents you. If you have any questions regarding the duties and responsibilities of the broker, you should resolve those questions before proceeding.

Real estate licensee asks that you acknowledge receipt of this information about brokerage services for the licensee's records.

Buyer, Seller, Landlord or Tenant

Date

Texas Real Estate Brokers and Salesmen are licensed and regulated by the Texas Real Estate Commission (TREC). If you have a question or complaint regarding a real estate licensee, you should contact TREC at P.O. Box 12188, Austin, Texas 78711-2188 or 512-465-3960